



# The Brighter Side

SUNRISE LIGHTING SYSTEMS, INC.

Volume 2, Issue 2

May 2010

## In This Issue

### Utopia:

Fluorescent	2
Wraparound	2
Linkable Under Cabinet Light	2
Emergency	3
Quick Ship	3
Down Lights	3
Decorative	3



Which is a division of Pacific Lighting Manufacturer Incorporation was founded in 2005 with clear direction and approach to the lighting business; offer quality product, quick shipping lead times, competitive pricing and excellent service to our customers.

We provide various types of Fluorescent, Decorative, Outdoor, HID, Exit Sign and Emergency lighting fixtures.

Utopia Lighting's product line consists of specification-grade products that are in stock and ready to ship. As we continuously expand our product lines, Utopia Lighting

consistently introduces new and advanced lighting fixtures.

Our wide selection of lighting fixtures assure our customers of the best combination of quality and value. We are committed to providing the highest level of quality and service and look forward to helping you bring all of your lighting projects to life.



## Utopia Defined

U•T•O•P•I•A (YŌŌ-TŌ'PĒ-Ə)

1. A. OFTEN UTOPIA, IDEALLY PERFECT

## Florescent Lighting

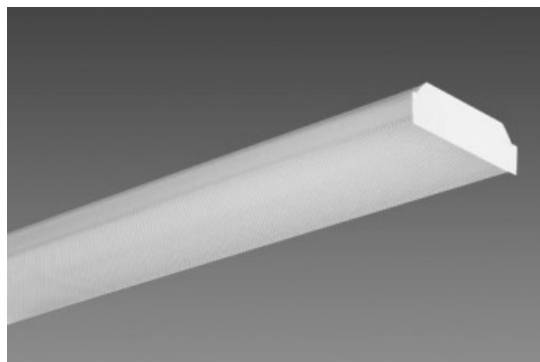

**WRAPAROUND**

Features Die formed, cold-rolled, heavy gauge steel with high-gloss baked white enamel finish over rust inhibiting phosphate coat. - End caps are same material as housing. - Injection molded acrylic basket diffuser, flat bottom and vertical sides. - Models available with 4' length 2 , 3, 4 lamps and 8' length tandem 4 lamps. - 100% acrylic, clear prismatic, linear side prisms and pyramidal bottom prisms for brightness control and minimize lamp image. - Lens are capable of being hinged from either side for easy cleaning or service.

Aluminum fixture, strong and durable, linkable function and easy installation.

Straight connector, 6" flexible connector and 6' power cord included.

Horizontal or vertical mounting bracket included

6400K T5 lamp included.

3000K/4100K/Red/Blue/Green lamps also available.

Easy twist locking lamp sockets. UL listed and labeled.

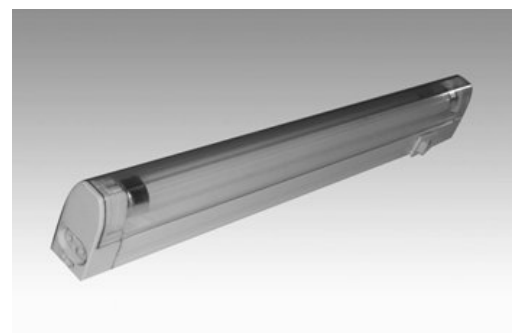

**T5 linkable Under Cabinet Light.**



Exit Signs and Emergency Lighting with the quality you expect from Utopia.

**Utopia Quick Ship!**

You will find products from Emergency, Fluorescent, HID and Decorative lines listed in the Quick Ship Program.



From Line voltage to Low Voltage and CFL you will find Utopia has Recessed Down Lighting to meet your needs

Whether it's the **Decorative Vanity Strip** or the **Circle Ceiling Light** you will find these fixtures are suitable for dry or damp locations and easy to assemble without tools. Although the Decorative Vanity Strip is for indoor use the Circle Ceiling Light is approved for outdoors .

Constructed of Steel and acrylic with a white opal diffuser and a satin nickel finish these fixtures are made with Utopia quality.

UL Listed and labeled

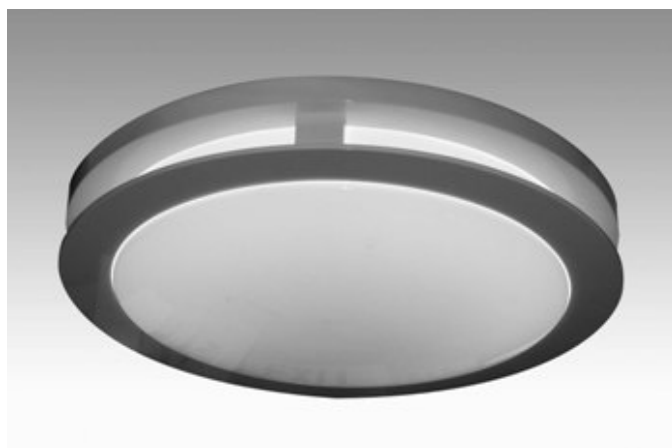

**C1 21" Circle Ceiling Light**

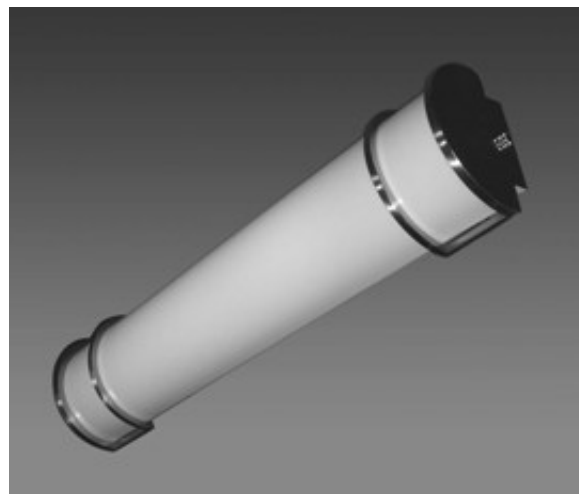

**Decorative Vanity Strip**



Doing it right the first time for you...

### **SUNRISE CONTACTS:**

**Robert McVicar** - Owner

robert@sunriselightingsystems.com

**Henry Kim** - Owner

henry@sunriselightingsystems.com

**Jeff Collins** - Northern Salesman

jeff@sunriselightingsystems.com

**Dean Shipp** - Southern Salesman

dean@sunriselightingsystems.com

**Jeremy Kinzel** - Quotations

jeremy@sunriselightingsystems.com

**Sam Westra** - Quotations

sam@sunriselightingsystems.com

**Megan Brisby** - Order Entry

megan@sunriselightingsystems.com

## ***YOUR THOUGHTS AND INPUT***

So many options and choices! Need more information? Look no further than a phone call or e-mail away.

Your question may be something that is on the minds of others as well and could be published in our new weekly newsletter. So, if you have a topic or a product that you would like to see more information on, please send the request to Jeff or Dean and we will be sure to include in a future issue.

Thank you!

[jeff@sunriselightingsystems.com](mailto:jeff@sunriselightingsystems.com)

[dean@sunriselightingsystems.com](mailto:dean@sunriselightingsystems.com)

Ctrl+(left click of the mouse) to follow link



## ***Sunrise Lighting Systems, Inc.***

360 W. BEDFORD AVE, SUITE 116

FRESNO, CA 93711

PHONE: 559-435-6090

FAX: 559-435-6089

[WWW.SUNRISELIGHTINGSYSTEMS.COM](http://WWW.SUNRISELIGHTINGSYSTEMS.COM)

Do it right  
the first time!